

ARM[®] DS-5[™]

Version 5

ARM DSTREAM[™] System and Interface Design Reference

ARM[®]

ARM DS-5

ARM DSTREAM System and Interface Design Reference

Copyright © 2010-2012 ARM. All rights reserved.

Release Information

The following changes have been made to this book.

| Change history | | | |
|-------------------|-------|------------------|-------------------------------------|
| Date | Issue | Confidentiality | Change |
| May 2010 | A | Non-Confidential | First release |
| November 2010 | B | Non-Confidential | Second release |
| 30 April 2011 | C | Non-Confidential | DSTREAM and RVI v4.2.1 Release |
| 29 July 2011 | D | Non-Confidential | Update 1 for DSTREAM and RVI v4.2.1 |
| 30 September 2011 | E | Non-Confidential | DSTREAM and RVI v4.4 Release |
| 29 February 2012 | F | Non-Confidential | Update 1 for DS-5 |
| 29 July 2012 | G | Non-Confidential | Update 2 for DS-5 |
| 12 October 2012 | H | Non-Confidential | Update 3 for DS-5 |

Proprietary Notice

Words and logos marked with or are registered trademarks or trademarks of ARM in the EU and other countries, except as otherwise stated below in this proprietary notice. Other brands and names mentioned herein may be the trademarks of their respective owners.

Neither the whole nor any part of the information contained in, or the product described in, this document may be adapted or reproduced in any material form except with the prior written permission of the copyright holder.

The product described in this document is subject to continuous developments and improvements. All particulars of the product and its use contained in this document are given by ARM in good faith. However, all warranties implied or expressed, including but not limited to implied warranties of merchantability, or fitness for purpose, are excluded.

This document is intended only to assist the reader in the use of the product. ARM shall not be liable for any loss or damage arising from the use of any information in this document, or any error or omission in such information, or any incorrect use of the product.

Where the term ARM is used it means “ARM or any of its subsidiaries as appropriate”.

This product includes software developed by the Apache Software Foundation (see <http://www.apache.org>).

Confidentiality Status

This document is Non-Confidential. The right to use, copy and disclose this document may be subject to license restrictions in accordance with the terms of the agreement entered into by ARM and the party that ARM delivered this document to.

Product Status

The information in this document is final, that is for a developed product.

Web Address

<http://www.arm.com>

Conformance Notices

This section contains conformance notices.

Federal Communications Commission Notice

This device is test equipment and consequently is exempt from part 15 of the FCC Rules under section 15.103 (c).

Class A

Important: This is a Class A device. In residential areas, this device may cause radio interference. The user should take the necessary precautions, if appropriate.

CE Declaration of Conformity



The system should be powered down when not in use.

It is recommended that ESD precautions be taken when handling DSTREAM and RVI equipment.

The DSTREAM and RVI modules generate, use, and can radiate radio frequency energy and may cause harmful interference to radio communications. There is no guarantee that interference will not occur in a particular installation. If this equipment causes harmful interference to radio or television reception, which can be determined by turning the equipment off or on, you are encouraged to try to correct the interference by one or more of the following measures:

- ensure attached cables do not lie across the target board
- reorient the receiving antenna
- increase the distance between the equipment and the receiver
- connect the equipment into an outlet on a circuit different from that to which the receiver is connected
- consult the dealer or an experienced radio/TV technician for help

Note

It is recommended that wherever possible shielded interface cables be used.

Contents

ARM DS-5 ARM DSTREAM System and Interface Design Reference

| | | |
|------------------|--|------|
| Chapter 1 | Conventions and feedback | |
| Chapter 2 | ARM DSTREAM System Design Guidelines | |
| 2.1 | Using adaptive clocking to synchronize the JTAG port | 2-2 |
| 2.2 | Reset signals | 2-5 |
| 2.3 | ARM reset signals | 2-6 |
| 2.4 | DSTREAM reset signals | 2-7 |
| 2.5 | Example reset circuits | 2-8 |
| 2.6 | ASIC guidelines | 2-9 |
| 2.7 | ICs containing multiple devices | 2-10 |
| 2.8 | Boundary scan test vectors | 2-11 |
| 2.9 | PCB guidelines | 2-12 |
| 2.10 | PCB connections | 2-13 |
| 2.11 | Target interface logic levels | 2-14 |
| Chapter 3 | ARM DSTREAM Target Interface Connections | |
| 3.1 | Signal descriptions | 3-2 |
| 3.2 | JTAG port timing characteristics | 3-3 |
| 3.3 | Serial Wire Debug | 3-5 |
| 3.4 | SWD connections | 3-6 |
| 3.5 | SWD timing requirements | 3-7 |
| 3.6 | Trace signals | 3-8 |
| 3.7 | Target connectors supported by DSTREAM | 3-10 |
| 3.8 | Mictor 38 | 3-11 |
| 3.9 | ARM JTAG 20 | 3-15 |
| 3.10 | TI JTAG 14 | 3-18 |
| 3.11 | ARM JTAG 14 | 3-21 |

| | | | |
|------------------|------|--|------|
| | 3.12 | CoreSight 10 | 3-24 |
| | 3.13 | CoreSight 20 | 3-26 |
| | 3.14 | MIPI 34 | 3-29 |
| | 3.15 | I/O diagrams | 3-33 |
| | 3.16 | Voltage domains | 3-36 |
| | 3.17 | Series termination | 3-37 |
| Chapter 4 | | ARM DSTREAM User I/O Connections | |
| | 4.1 | The User I/O connector | 4-2 |
| Chapter 5 | | Designing the Target Board for Tracing with ARM DSTREAM | |
| | 5.1 | Overview of high-speed design | 5-2 |
| | 5.2 | PCB track impedance | 5-3 |
| | 5.3 | Signal requirements | 5-4 |
| | 5.4 | Probe modeling | 5-5 |

Chapter 1

Conventions and feedback

The following describes the typographical conventions and how to give feedback:

Typographical conventions

The following typographical conventions are used:

`monospace` Denotes text that can be entered at the keyboard, such as commands, file and program names, and source code.

monospace Denotes a permitted abbreviation for a command or option. The underlined text can be entered instead of the full command or option name.

monospace italic

Denotes arguments to commands and functions where the argument is to be replaced by a specific value.

`monospace bold`

Denotes language keywords when used outside example code.

italic Highlights important notes, introduces special terminology, denotes internal cross-references, and citations.

bold Highlights interface elements, such as menu names. Also used for emphasis in descriptive lists, where appropriate, and for ARM[®] processor signal names.

Feedback on this product

If you have any comments and suggestions about this product, contact your supplier and give:

- your name and company

- the serial number of the product
- details of the release you are using
- details of the platform you are using, such as the hardware platform, operating system type and version
- a small standalone sample of code that reproduces the problem
- a clear explanation of what you expected to happen, and what actually happened
- the commands you used, including any command-line options
- sample output illustrating the problem
- the version string of the tools, including the version number and build numbers.

Feedback on content

If you have comments on content then send an e-mail to errata@arm.com. Give:

- the title
- the number, ARM DUI 0499H
- if viewing online, the topic names to which your comments apply
- if viewing a PDF version of a document, the page numbers to which your comments apply
- a concise explanation of your comments.

ARM also welcomes general suggestions for additions and improvements.

ARM periodically provides updates and corrections to its documentation on the ARM Information Center, together with knowledge articles and *Frequently Asked Questions* (FAQs).

Other information

- ARM Information Center, <http://infocenter.arm.com/help/index.jsp>
- ARM Technical Support Knowledge Articles, <http://infocenter.arm.com/help/topic/com.arm.doc.faqs/index.html>
- ARM Support and Maintenance, <http://www.arm.com/support/services/support-maintenance.php>
- ARM Glossary, <http://infocenter.arm.com/help/topic/com.arm.doc.aeg0014-/index.html>.

Chapter 2

ARM DSTREAM System Design Guidelines

The following topics provide information on developing ARM® architecture-based devices and *Printed Circuit Boards* (PCBs) that can be debugged using ARM DSTREAM™:

- *Using adaptive clocking to synchronize the JTAG port on page 2-2*
- *Reset signals on page 2-5*
- *ARM reset signals on page 2-6*
- *DSTREAM reset signals on page 2-7*
- *Example reset circuits on page 2-8*
- *ASIC guidelines on page 2-9*
- *ICs containing multiple devices on page 2-10*
- *Boundary scan test vectors on page 2-11*
- *PCB guidelines on page 2-12*
- *PCB connections on page 2-13*
- *Target interface logic levels on page 2-14.*

2.1 Using adaptive clocking to synchronize the JTAG port

ARM architecture-based devices using only hard macrocells, for example ARM7TDMI® and ARM920T, use the standard five-wire JTAG interface (**TCK**, **TMS**, **TDI**, **TDO**, and **nTRST**). Some target systems, however, require that JTAG events are synchronized to a clock in the system. To ensure a valid JTAG **CLK** setting, these systems often support an extra signal (**RTCK**) at the JTAG port:

- an *Application-Specific Integrated Circuit* (ASIC) with single rising-edge D-type design rules, such as one based on an ARM7TDMI-S™ processor
- a system where scan chains external to the ARM macrocell must meet single rising-edge D-type design rules.

The adaptive clocking feature of DSTREAM addresses this requirement. When adaptive clocking is enabled, DSTREAM issues a **TCK** signal and waits for the **RTCK** signal to come back. DSTREAM does not progress to the next **TCK** until **RTCK** is received.

Note

- Adaptive clocking is automatically configured in ARM DS-5™ as required by the target.
 - If you use the adaptive clocking feature, transmission delays, gate delays, and synchronization requirements result in a lower maximum clock frequency than with non-adaptive clocking. Do not use adaptive clocking unless it is required by the hardware design.
 - If, when autoconfiguring a target, the DSTREAM unit receives pulses on **RTCK** in response to **TCK** it assumes that adaptive clocking is required, and enables adaptive clocking in the target configuration. If the hardware does not require adaptive clocking, the target is driven slower than it could be. You can disable adaptive clocking using controls on the JTAG settings dialog box.
 - If adaptive clocking is used, DSTREAM cannot detect the clock speed, and therefore cannot scale its internal timeouts. If the target clock frequency is very slow, a JTAG timeout might occur. This leaves the JTAG in an unknown state, and DSTREAM cannot operate correctly without reconnecting to the processor. JTAG timeouts are enabled by default. You can disable JTAG timeouts by deselecting the option JTAG Timeouts Enabled in the installed Debug Hardware Config utility provided with the DSTREAM unit.
-

You can use adaptive clocking as an interface to targets with slow or widely varying clock frequency, such as battery-powered equipment that varies its clock speed according to processing demand. In this system, **TCK** might be hundreds of times faster than the system clock, and the debugger loses synchronization with the target system. Adaptive clocking ensures that the JTAG port speed automatically adapts to slow system speed.

The following figure shows a circuit for a basic JTAG port synchronizer.

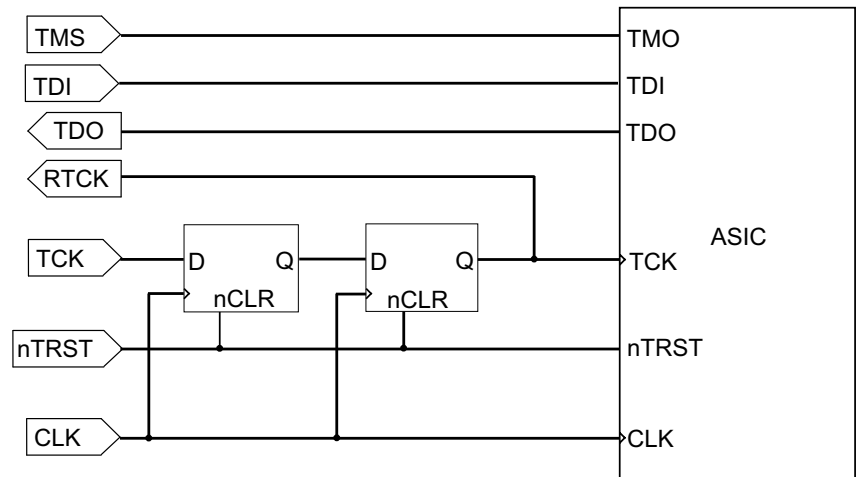

Figure 2-1 Basic JTAG port synchronizer

The following figure shows a partial timing diagram for the basic JTAG synchronizer. The delay can be reduced by clocking the flip-flops from opposite edges of the system clock, because the second flip-flop only provides better immunity to metastability problems. Even a single flip-flop synchronizer never completely misses **TCK** events, because **RTCK** is part of a feedback loop controlling **TCK**.

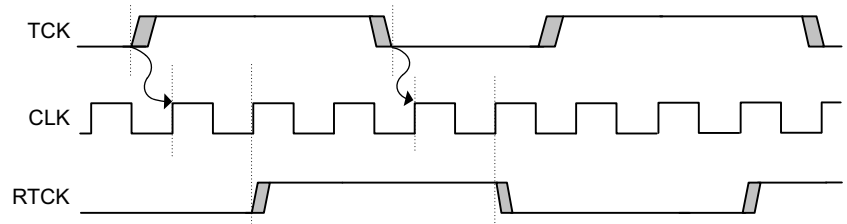

Figure 2-2 Timing diagram for the Basic JTAG synchronizer

It is common for an ASIC design flow and its design rules to impose a restriction that all flip-flops in a design are clocked by one edge of a single clock. To interface this to a JTAG port that is completely asynchronous to the system, it is necessary to convert the JTAG **TCK** events into clock enables for this single clock, and to ensure that the JTAG port cannot overrun this synchronization delay.

The following figure shows one possible implementation of this circuit.

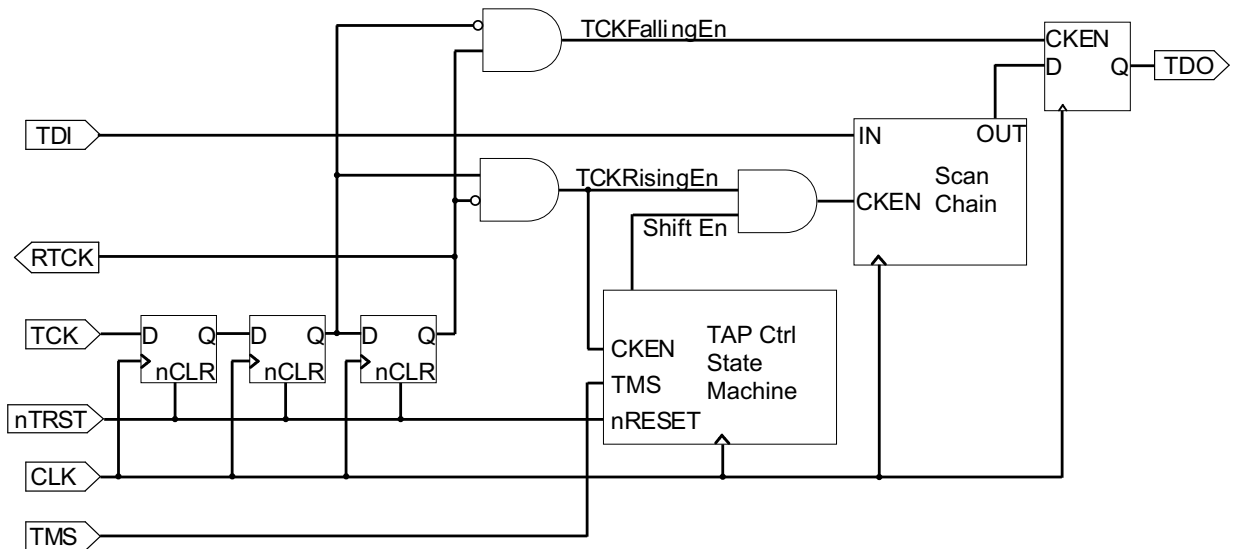

Figure 2-3 JTAG port synchronizer for single rising-edge D-type ASIC design rules

The following figure shows a corresponding partial timing diagram, and how **TCKFallingEn** and **TCKRisingEn** are each active for exactly one period of **CLK**. It also shows how these enable signals gate the **RTCK** and **TDO** signals so that they only change state at the edges of **TCK**.

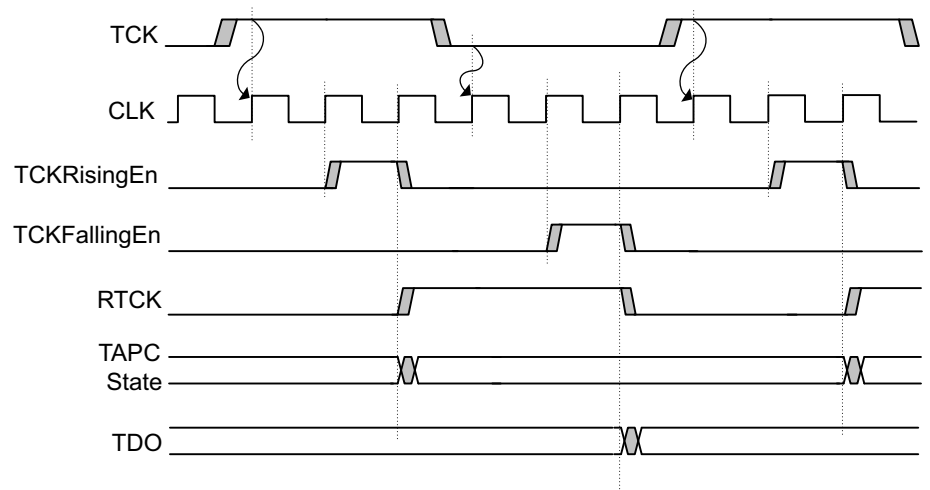

Figure 2-4 Timing diagram for the D-type JTAG synchronizer

2.1.1 See also

Concepts

- [Reset signals on page 2-5.](#)

2.2 Reset signals

There are two types of reset signals available on ARM devices. The manner in which DSTREAM expects these signals to be wired is described in the following topics:

- [ARM reset signals on page 2-6](#)
- [DSTREAM reset signals on page 2-7.](#)

2.3 ARM reset signals

All ARM processors have a main processor reset that might be called **nRESET**, **BnRES**, or **HRESET**. This is asserted by one or more of these conditions:

- power on
- manual push button
- remote reset from the debugger (using)
- watchdog circuit (if appropriate to the application).

Any ARM processor including the JTAG interface has a second reset input called **nTRST** (TAP Reset). This resets the EmbeddedICE logic, the *Test Access Port* (TAP) controller, and the boundary scan cells. It is activated by remote JTAG reset (from).

It is strongly recommended that both signals are separately available on the JTAG connector. If the **nRESET** and **nTRST** signals are linked together, resetting the system also resets the TAP controller. This means that:

- it is not possible to debug a system from reset, because any breakpoints previously set are lost
- you might have to start the debug session from the beginning, because DSTREAM might not recover when the TAP controller state is changed.

2.3.1 See also

Concepts

- [DSTREAM reset signals on page 2-7](#)
- [Example reset circuits on page 2-8.](#)

2.4 DSTREAM reset signals

The DSTREAM unit has two reset signals connected to the debug target hardware:

- **nTRST** drives the JTAG **nTRST** signal on the ARM processor. It is an output that is activated whenever the debug software has to re-initialize the debug interface in the target system.
- **nSRST** is a bidirectional signal that both drives and senses the system reset signal on the target. By default, this output is driven LOW by the debugger to re-initialize the target system.

The target hardware must pull the reset lines to their inactive state to assure normal operation when the JTAG interface is disconnected. In the DSTREAM unit, the strong pull-up/pull-down resistance is approximately 33Ω , and the weak pull-up/pull-down resistance is approximately $4.7k\Omega$. Because you can select the drive strength for **nTRST** and **nSRST**, target assemblies with a variety of different reset configurations can be supported.

2.4.1 See also

Concepts

- [ARM reset signals on page 2-6](#)
- [Example reset circuits on page 2-8.](#)

Reference

Using the Debug Hardware Configuration Utilities:

- [Debug hardware Advanced configuration reset options on page 5-36.](#)

2.5 Example reset circuits

The circuit in the following figure shows a typical reset circuit logic for the ARM reset signals and the DSTREAM reset signals.

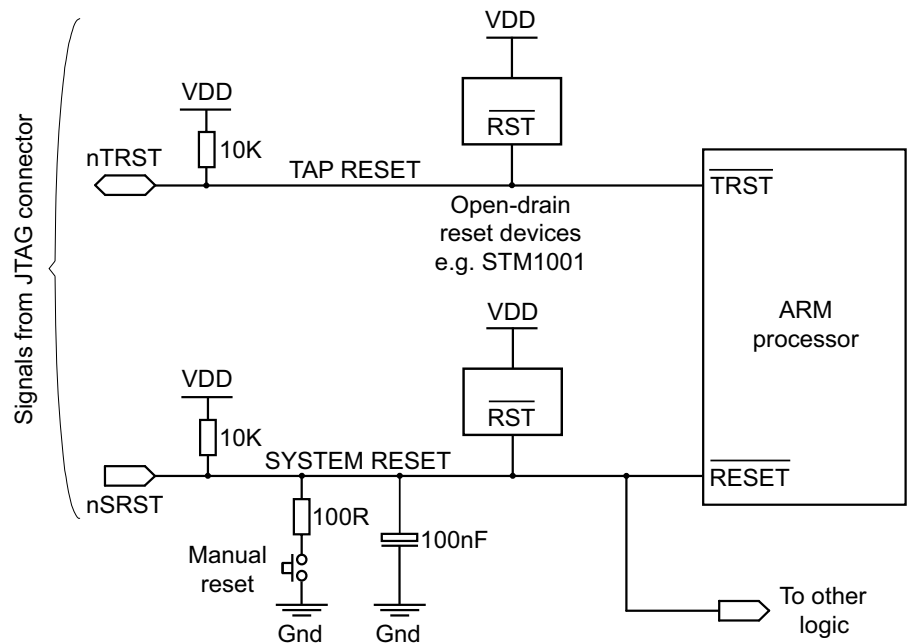

Figure 2-5 Example reset circuit logic

2.5.1 See also

Concepts

- [ARM reset signals on page 2-6](#)
- [DSTREAM reset signals on page 2-7](#).

2.6 ASIC guidelines

ASIC guidelines are described in the following topics:

- *ICs containing multiple devices* on page 2-10
- *Boundary scan test vectors* on page 2-11.

2.7 ICs containing multiple devices

If your ASIC contains multiple devices that have a JTAG *Test Access Port* (TAP) controller, you must serially chain them so that can communicate with all of them simultaneously. The chaining can either be within the ASIC, or externally.

———— Note ————

There is no support in DSTREAM for multiplexing **TCK**, **TMS**, **TDI**, **TDO**, and **RTCK** between a number of different processors.

2.7.1 TAP controllers serially chained within the ASIC

The JTAG standard originally described serially chaining multiple devices on a PCB. This concept can be extended to serially chaining multiple TAP controllers within an ASIC, as shown in the following figure:

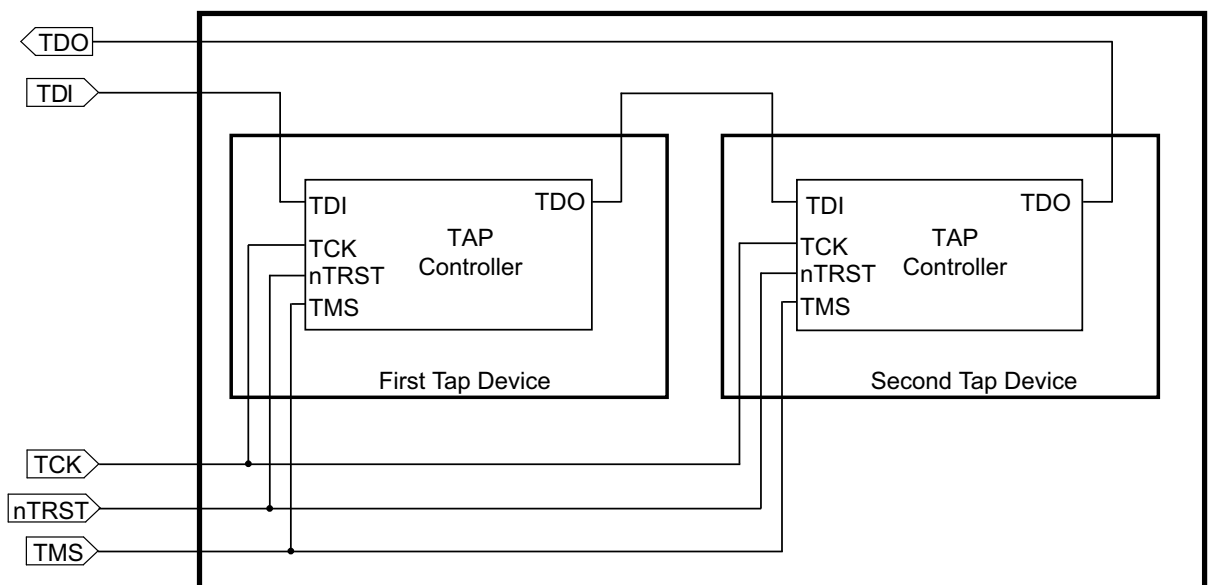

Figure 2-6 TAP Controllers serially chained within an ASIC

This configuration does not increase the package pin count. It does increase JTAG propagation delays, but this impact can be small if you put unaddressed TAP controllers into bypass mode.

2.7.2 TAP controllers serially chained externally

You can use separate pins on the ASIC for each JTAG port, and serially chain them externally (for example on the PCB). This configuration can simplify device testing, and gives the greatest flexibility on the PCB. However, this is at the cost of many pins on the device package.

2.7.3 See also

Concepts

- [Boundary scan test vectors on page 2-11.](#)

Other information

- *CoreSight Technology System Design Guide*,
<http://infocenter.arm.com/help/topic/com.arm.doc.dgi0012-/index.html>

2.8 Boundary scan test vectors

If you use the JTAG boundary scan test methodology to apply production test vectors, you might want to have independent external access to each *Test Access Port* (TAP) controller. This avoids the requirement to merge test vectors for more than one block in the device. One solution to this is to adopt a hybrid, using a pin on the package that switches elements of the device into a test mode. This can be used to break the internal daisy chaining of **TDO** and **TDI** signals, and to multiplex out independent JTAG ports on pins that are used for another purpose during normal operation.

2.8.1 See also

Concepts

- [ICs containing multiple devices on page 2-10.](#)

Other information

- *CoreSight Technology System Design Guide*,
<http://infocenter.arm.com/help/topic/com.arm.doc.dgi0012-/index.html>

2.9 PCB guidelines

PCB guidelines on the physical and electrical connections present on the target board are described in the following topics:

- [PCB connections on page 2-13](#)
- [Target interface logic levels on page 2-14.](#)

2.10 PCB connections

The following figure shows a typical JTAG connection scheme:

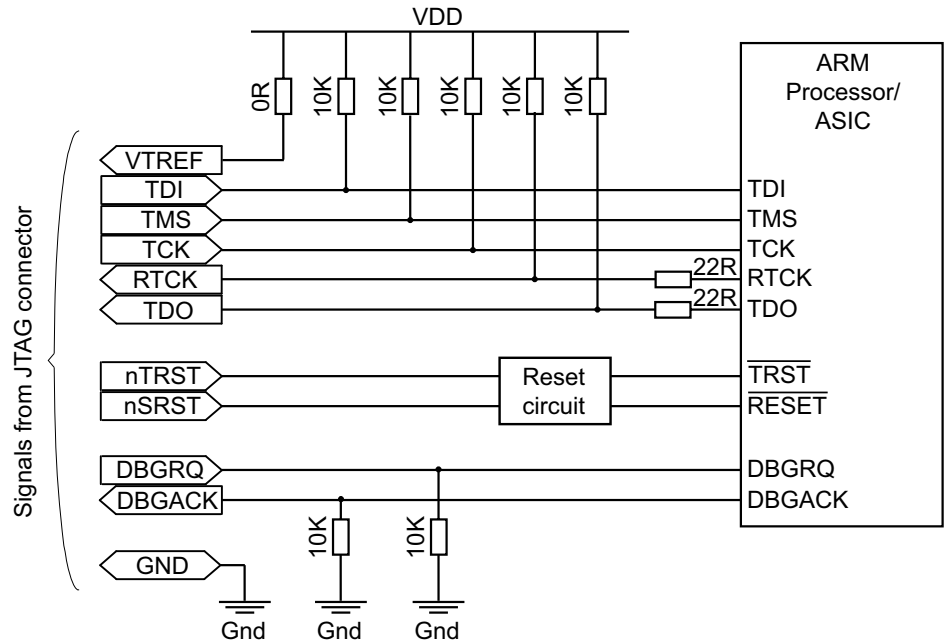

Figure 2-7 Typical PCB connections

Note

- The signals **TDI**, **TMS**, **TCK**, **RTCK** and **TDO** are typically pulled up on the target board to keep them stable when the debug equipment is not connected.
- **DBGRQ** and **DBGACK** are typically pulled down on the target.
- If there is no **RTCK** signal provided on the processor, it can either be pulled to a fixed logic level or connected to the **TCK** signal to provide a direct loop-back.
- All pull-up and pull-down resistors must be in the range 1K-100K Ω .
- The **VTREF** signal is typically connected directly to the **VDD** rail. If a series resistor is used to protect against short-circuits, it must have a value no greater than 100 Ω .
- To improve signal integrity, it is good practice to provide an impedance matching resistor on the **TDO** and **RTCK** outputs of the processor. The value of these resistors, added to the impedance of the driver must be approximately equal to 50 Ω .

2.10.1 See also

Concepts

- [ASIC guidelines on page 2-9](#)
- [Target interface logic levels on page 2-14.](#)

Reference

- [Chapter 3 ARM DSTREAM Target Interface Connections](#)
- [Chapter 5 Designing the Target Board for Tracing with ARM DSTREAM.](#)

2.11 Target interface logic levels

DSTREAM is designed to interface with a wide range of target system logic levels. It does this by adapting its output drive and input threshold to a reference voltage supplied by the target system.

V_{Tref} feeds the reference voltage to the DSTREAM unit. This voltage is clipped internally at approximately 3.4V, and is used as the output high voltage (V_{oh}) for logic 1s (ones) on **TCK**, **TDI**, and **TMS**. 0V is used as the output low voltage for logic 0s (zeroes). The input logic threshold voltage ($V_{i(th)}$) for the **TDO**, **RTCK**, and **nSRST** inputs is 50% of the V_{oh} level, and so is clipped to approximately 1.7V. The relationships of V_{oh} and $V_{i(th)}$ to V_{Tref} are shown in the following figure:

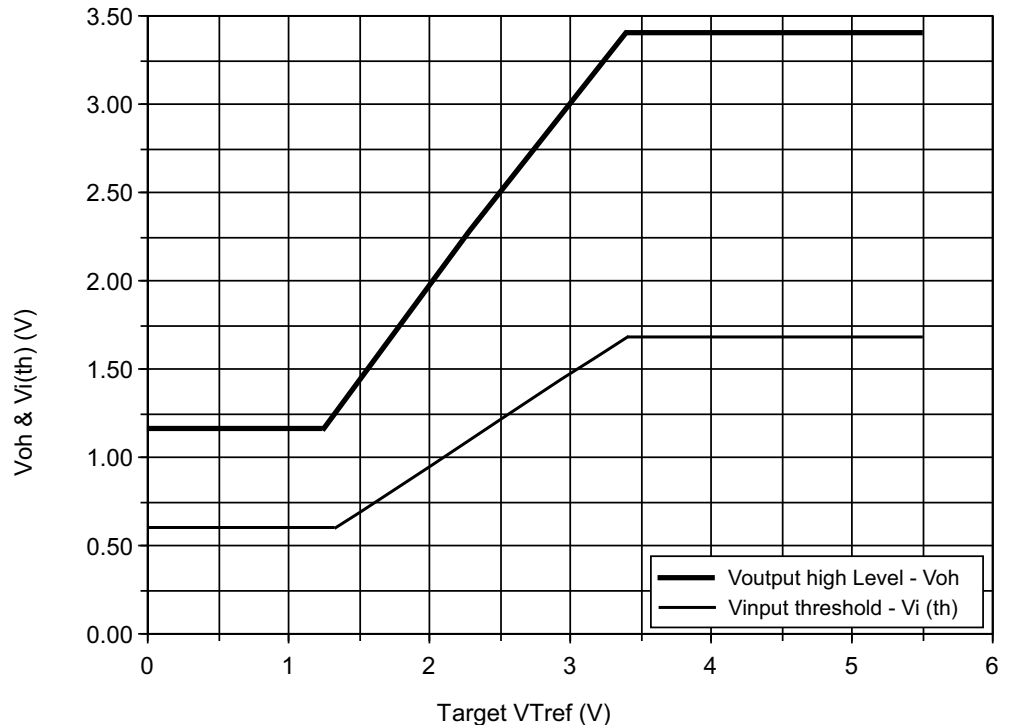

Figure 2-8 Target interface logic levels

DSTREAM can adapt interface levels down to V_{Tref} of 1.2V.

By default, the **nTRST** and **nSRST** signals are pulled-up by 4.7K resistors within DSTREAM and driven (strong) low during resets. This allows the reset signals to be driven by other open-drain devices or switches on the target board. The polarity and high/low drive strengths can be configured within the software.

The input and output characteristics of the DSTREAM unit are compatible with logic levels from TTL-compatible, or CMOS logic in target systems. When assessing compatibility with other logic systems, the output impedance of all signals is approximately 50 Ω .

2.11.1 See also

Concepts

- [ASIC guidelines on page 2-9](#)
- [PCB connections on page 2-13](#).

Reference

- [Chapter 3 ARM DSTREAM Target Interface Connections](#)
- [Chapter 5 Designing the Target Board for Tracing with ARM DSTREAM.](#)

Chapter 3

ARM DSTREAM Target Interface Connections

The following topics provide descriptions of the interface connections on the DSTREAM unit:

- *Signal descriptions* on page 3-2
- *JTAG port timing characteristics* on page 3-3
- *Serial Wire Debug* on page 3-5
- *SWD connections* on page 3-6
- *SWD timing requirements* on page 3-7
- *Trace signals* on page 3-8
- *Target connectors supported by DSTREAM* on page 3-10
- *Mictor 38* on page 3-11
- *ARM JTAG 20* on page 3-15
- *TI JTAG 14* on page 3-18
- *ARM JTAG 14* on page 3-21
- *CoreSight 10* on page 3-24
- *CoreSight 20* on page 3-26
- *MIPI 34* on page 3-29
- *I/O diagrams* on page 3-33
- *Voltage domains* on page 3-36
- *Series termination* on page 3-37.

3.1 Signal descriptions

Signal descriptions for JTAG, Serial Wire Debug and trace are described in the following topics:

- [JTAG port timing characteristics on page 3-3](#)
- [Serial Wire Debug on page 3-5](#)
- [Trace signals on page 3-8.](#)

3.2 JTAG port timing characteristics

You must consider the timing characteristics of a DSTREAM unit if you design a target device or board and want to be able to connect DSTREAM at a particular **TCK** frequency. The characteristics relate to the DSTREAM hardware. You must consider them in parallel with the characteristics of your target.

The following figure shows the JTAG port timing and parameters:

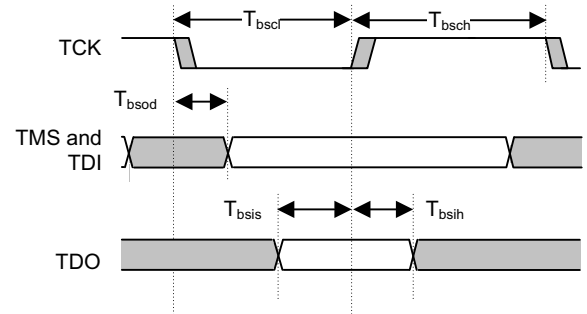

Figure 3-1 JTAG port timing diagram

In a JTAG device that fully complies to IEEE1149.1-2001, **TDI** and **TMS** are sampled on the rising edge of **TCK**, and **TDO** changes on the falling edge of **TCK**. To take advantage of these properties, DSTREAM samples **TDO** on the rising edge of **TCK** and changes its **TDI** and **TMS** signals on the falling edge of **TCK**. This means that with a fully compliant target, issues with minimum setup and hold times can always be resolved by decreasing the **TCK** frequency, because this increases the separation between signals changing and being sampled.

———— **Note** —————

There are no separate timing requirements for adaptive clocking mode, because the minimum T_{bsch} and T_{bscl} times are identical and are the same as for non-adaptive clocking. T_{bsis} and T_{bsih} are relative to **RTCK** rising, and not **TCK** rising, as **RTCK** is used to sample **TDO** in adaptive clocking mode.

The only real timing difference is that in adaptive mode, DSTREAM samples **TDO** on the rising edge of **RTCK** and not **TCK**, so **TDO** timing is relative to **RTCK**.

The following table shows the timing requirements for the JTAG signals on the DSTREAM probe:

Table 3-1 JTAG A timing requirements

| Parameter | Min | Max | Description |
|------------|--------|-------------|---|
| T_{bscl} | 50ns | 500 μ s | TCK LOW period |
| T_{bsch} | 50ns | 500 μ s | TCK HIGH period |
| T_{bsod} | - | 6.0ns | TDI and TMS valid from TCK (falling) |
| T_{bsis} | 15.0ns | - | TDO setup to TCK (rising) |
| T_{bsih} | 6.0ns | - | TDO hold from TCK (rising) |

Note

- The debug software enables you to change the **TCK** frequency. The **TCK** LOW:HIGH mark-space ratio is always 50:50. The other parameters must be considered with the specific values of T_{bscl} and T_{bsch} that you have chosen. The default values for an autoconfigured single-TAP system are, nominally, $T_{bscl}=50ns$ and $T_{bsch}=50ns$.
 - T_{bsod} is the maximum delay between the falling edge of **TCK** and valid levels on the **TDI** and **TMS** DSTREAM output signals. The target samples these signals on the following rising edge of **TCK** and so the minimum setup time for the target, relative to the rising edge of **TCK**, is $T_{bscl}-T_{bsod}$.
 - T_{bsis} is the minimum setup time for the **TDO** input signal, relative to the rising edge of **TCK** when DSTREAM samples this signal. The target changes its **TDO** value on the previous falling edge of **TCK** and so the maximum time for the target **TDO** level to become valid, relative to the falling edge of **TCK**, is $T_{bscl}-T_{bsis}$.
-

3.2.1 See also

Concepts

- [Signal descriptions on page 3-2](#)
- [Serial Wire Debug on page 3-5](#)
- [Trace signals on page 3-8.](#)

3.3 Serial Wire Debug

The *Serial Wire Debug* (SWD) connection to the *Debug Access Port* (DAP) is described in the following topics:

- [SWD connections on page 3-6](#)
- [SWD timing requirements on page 3-7](#).

3.4 SWD connections

The following figure shows a typical *Serial Wire Debug* (SWD) connection scheme:

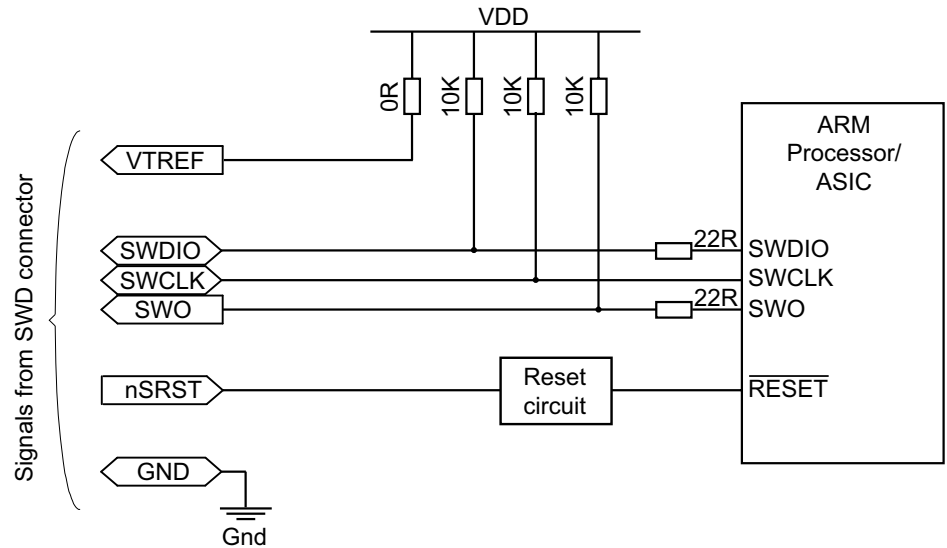

Figure 3-2 Typical SWD connections

Note

- The **SWDIO**, **SWCLK** and **SWO** signals are typically pulled up on the target to keep them stable when the debug equipment is not connected.
- All pull-up resistors must be in the range 1K-100K Ω .
- The **VTREF** signal is typically connected directly to the VDD rail. If a series resistor is used to protect against short-circuits, it must have a value no greater than 100 Ω .
- To improve signal integrity, it is good practice to provide an impedance matching resistor on the **SWDIO** and **SWO** outputs of the processor. The value of these resistors, added to the impedance of the driver must be approximately equal to 50 Ω .

3.4.1 See also

Concepts

- [JTAG port timing characteristics on page 3-3](#)
- [Serial Wire Debug on page 3-5](#)
- [SWD timing requirements on page 3-7](#)
- [Trace signals on page 3-8.](#)

3.5 SWD timing requirements

The interface uses only two lines, but for clarity the diagrams shown in the following figure separate the SWDIO line to show when it is driven by either the DSTREAM probe or target:

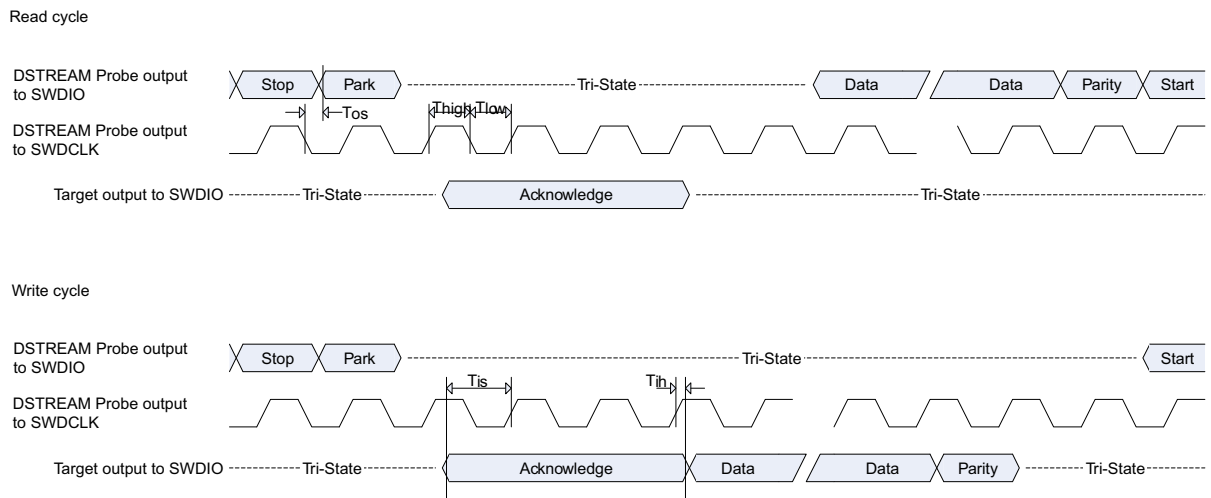

Figure 3-3 SWD timing diagrams

The probe writes data to SWDIO on the falling edge of SWDCLK. The probe reads data from SWDIO on the rising edge of SWDCLK. The target writes data to SWDIO on the rising edge of SWDCLK. The target reads data from SWDIO on the rising edge of SWDCLK.

The following table shows the timing requirements for the *Serial Wire Debug* (SWD):

Table 3-2 SWD timing requirements

| Parameter | Min | Max | Description |
|------------|------|-------------|--|
| T_{high} | 10ns | 500 μ s | SWDCLK HIGH period |
| T_{low} | 10ns | 500 μ s | SWDCLK LOW period |
| T_{os} | -5ns | 5ns | SWDIO Output skew to falling edge SWDCLK |
| T_{is} | 4ns | - | Input Setup time required between SWDIO and rising edge SWDCLK |
| T_{ih} | 1ns | - | Input Hold time required between SWDIO and rising edge SWDCLK |

3.5.1 See also

Concepts

- [JTAG port timing characteristics on page 3-3](#)
- [Serial Wire Debug on page 3-5](#)
- [SWD connections on page 3-6](#)
- [Trace signals on page 3-8.](#)

3.6 Trace signals

Data transfer is synchronized by the **TRACECLK** signal. See the following:

- [Clock frequency](#)
- [Switching thresholds](#)
- [Hot-plugging](#).

3.6.1 Clock frequency

For capturing trace port signals synchronous to **TRACECLK**, the DSTREAM trace feature supports up to 600Mbps per trace signal using DDR clocking mode, or up to 480Mbps using SDR clocking mode. The following figure and table describe the timing for **TRACECLK**:

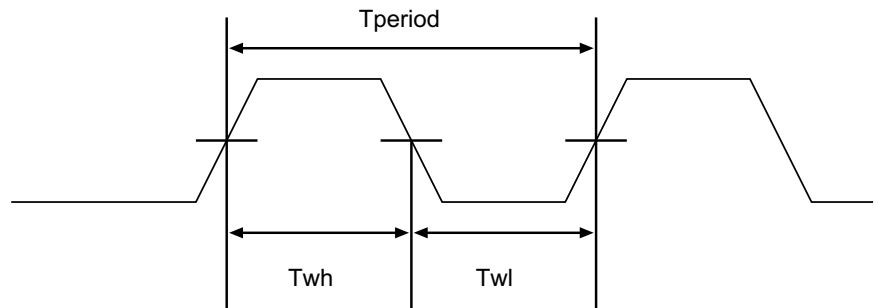

Figure 3-4 Clock waveforms

Table 3-3 TRACECLK frequencies

| Parameter | DSTREAM | Description |
|--------------------|---------|------------------|
| T_{period} (min) | 2.08ns | Clock period |
| T_{wh} (min) | 1.0ns | High pulse width |
| T_{wl} (min) | 1.0ns | Low pulse width |

3.6.2 Switching thresholds

The trace probe detects the target signaling reference voltage (V_{Tref}) and automatically adjusts its switching thresholds to $V_{Tref}/2$. For example, on a 3.3 volt target system, the switching thresholds are set to 1.65 volts.

3.6.3 Hot-plugging

If you power-up the DSTREAM unit when it is plugged into an unpowered target, or if you plug an unpowered DSTREAM unit into a powered target, trace functionality is not damaged.

If you connect an unpowered DSTREAM unit to a powered target, there is a maximum leakage current into the DSTREAM unit of $\pm 10\mu A$ on any of the debug or trace signals.

3.6.4 See also

Concepts

- [Target interface logic levels on page 2-14](#)
- [Signal descriptions on page 3-2](#)
- [JTAG port timing characteristics on page 3-3](#)

- [Serial Wire Debug](#) on page 3-5.

Other information

- ETMv1 and ETMv3 architecture pinouts,
<http://infocenter.arm.com/help/topic/com.arm.doc.ih0014-/index.html>

3.7 Target connectors supported by DSTREAM

The target connectors supported by DSTREAM are described in the following topics:

- [Mictor 38 on page 3-11](#)
- [ARM JTAG 20 on page 3-15](#)
- [TI JTAG 14 on page 3-18](#)
- [ARM JTAG 14 on page 3-21](#)
- [CoreSight 10 on page 3-24](#)
- [CoreSight 20 on page 3-26](#)
- [MIPI 34 on page 3-29](#).

3.8 Mictor 38

The Mictor 38 connector is intended for high-speed trace capture of up to 16 bits of trace data and status/sync signals. It can also be used to connect to the debug signals of the target.

———— **Note** ————

This connector supports only one voltage domain. If the trace and debug signals of the target system use different logic levels, the target must be designed to use a separate debug connector. If a separate connector is used for the debug signals, the unused debug pins of the Mictor 38 connector can be left open circuit.

The central earthing strip on the connector provides signal ground. This strip has five through-hole pins, and to achieve reliable trace operation these pins must be soldered directly to the ground plane of the target board.

The following figure shows the Mictor 38 connector pinout:

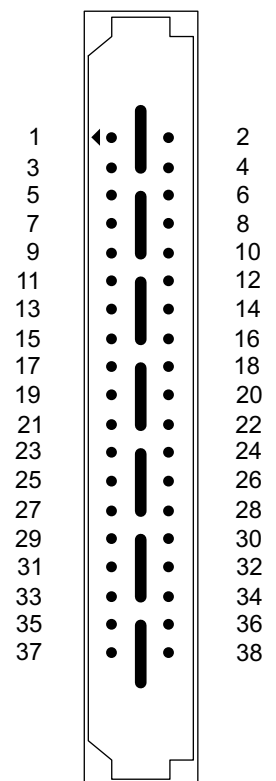

Figure 3-5 Mictor 38 connector pinout

Due to the construction of the Mictor cable, the signals on the probe itself are column-reversed (1-37, 37-1, 2-38, 38-2, and so on). Only take this into account if testing signals at the probe.

The following table shows the Mictor 38 pinout as used on the target board:

Table 3-4 Mictor 38 interface pinout table

| Pin | ETMv3/TPIU | ETMv2 | ETMv1 | I/O diagram | Voltage domain |
|-----|---------------|--------------|--------------|-------------|----------------|
| 1 | NC | NC | NC | NA | NA |
| 2 | NC | NC | NC | NA | NA |
| 3 | NC | NC | NC | NA | NA |
| 4 | NC | NC | NC | NA | NA |
| 5 | GND | GND | GND | H | NA |
| 6 | TRACECLK | TRACECLK | TRACECLK | A | B |
| 7 | DBGREQ | DBGREQ | DBGREQ | B | B |
| 8 | DBGACK | DBGACK | DBGACK | A | B |
| 9 | nSRST | nSRST | nSRST | E | B |
| 10 | EXTTRIG | EXTTRIG | EXTTRIG | B | B |
| 11 | TDO | TDO | TDO | A | B |
| 12 | VTREF | VTREF | VTREF | F | B |
| 13 | RTCK | RTCK | RTCK | B | B |
| 14 | VSUPPLY | VSUPPLY | VSUPPLY | Reserved | NA |
| 15 | TCK | TCK | TCK | B | B |
| 16 | TRACEDATA[7] | TRACEPKT[7] | TRACEPKT[7] | A | B |
| 17 | TMS | TMS | TMS | B | B |
| 18 | TRACEDATA[6] | TRACEPKT[6] | TRACEPKT[6] | A | B |
| 19 | TDI | TDI | TDI | B | B |
| 20 | TRACEDATA[5] | TRACEPKT[5] | TRACEPKT[5] | A | B |
| 21 | nTRST | nTRST | nTRST | D | B |
| 22 | TRACEDATA[4] | TRACEPKT[4] | TRACEPKT[4] | A | B |
| 23 | TRACEDATA[15] | TRACEPKT[15] | TRACEPKT[15] | A | B |
| 24 | TRACEDATA[3] | TRACEPKT[3] | TRACEPKT[3] | A | B |
| 25 | TRACEDATA[14] | TRACEPKT[14] | TRACEPKT[14] | A | B |
| 26 | TRACEDATA[2] | TRACEPKT[2] | TRACEPKT[2] | A | B |
| 27 | TRACEDATA[13] | TRACEPKT[13] | TRACEPKT[13] | A | B |
| 28 | TRACEDATA[1] | TRACEPKT[1] | TRACEPKT[1] | A | B |
| 29 | TRACEDATA[12] | TRACEPKT[12] | TRACEPKT[12] | A | B |
| 30 | Logic 0 | TRACEPKT[0] | TRACEPKT[0] | A | B |
| 31 | TRACEDATA[11] | TRACEPKT[11] | TRACEPKT[11] | A | B |

Table 3-4 Mictor 38 interface pinout table (continued)

| Pin | ETMv3/TPIU | ETMv2 | ETMv1 | I/O diagram | Voltage domain |
|-----|---------------|--------------|-------------|-------------|----------------|
| 32 | Logic 0 | PIPESTAT[3] | TRACESYNC | A | B |
| 33 | TRACEDATA[10] | TRACEPKT[10] | | A | B |
| 34 | Logic 1 | PIPESTAT[2] | PIPESTAT[2] | A | B |
| 35 | TRACEDATA[9] | TRACEPKT[9] | TRACEPKT[9] | A | B |
| 36 | TRACECTL | PIPESTAT[1] | PIPESTAT[1] | A | B |
| 37 | TRACEDATA[8] | TRACEPKT[8] | TRACEPKT[8] | A | B |
| 38 | TRACEDATA[0] | PIPESTAT[0] | PIPESTAT[0] | A | B |

The following table describes the signals on the Mictor 38 interfaces:

Table 3-5 Mictor 38 signals

| Signal | I/O | Description |
|---|--------|--|
| TRACEPKT , TRACEDATA , PIPESTAT , TRACESYNC , TRACECTL | Input | These pins provide DSTREAM with ETM/TPIU trace data in the various formats shown above. You are advised to series terminate these signals close to the target processor. |
| TRACECLK | Input | The Trace Clock pin provides DSTREAM with the clock signal necessary to sample all of the trace data signals above. You are advised to series terminate TRACECLK close to the target processor. |
| TDI | Output | The Test Data In pin provides serial data to the target during debugging. TDI can be pulled HIGH on the target. |
| TDO | Input | The Test Data Out pin receives serial data from the target during debugging. You are advised to series terminate TDO close to the target processor. TDO is typically pulled HIGH on the target. |
| TMS | Output | The Test Mode Select pin is used to set the state of the <i>Test Access Port</i> (TAP) controller on the target. TMS can be pulled HIGH on the target to keep the TAP controller inactive when not in use. |
| TCK | Output | The Test Clock pin is used to clock data into the TDI and TMS inputs of the target. TCK is typically pulled HIGH on the target. |
| RTCK | Input | The Return Test Clock pin is used to echo the test clock signal back to DSTREAM for use with adaptive mode clocking. If RTCK is generated by the target processor, you are advised to series terminate it. RTCK can be pulled HIGH or LOW on the target when not in use. |

Table 3-5 Mictor 38 signals (continued)

| Signal | I/O | Description |
|----------------|--------------|---|
| nTRST | Output | The Test Reset pin can be used to reset the TAP controller of the processor to allow debugging to take place. nTRST is typically pulled HIGH on the target and pulled strong-LOW by DSTREAM to initiate a reset. The polarity and strength of nTRST is configurable. |
| nSRST | Input/Output | The System Reset pin is used to fully reset the target. This signal can be initiated by DSTREAM or by the target board (which is then detected by DSTREAM). nSRST is typically pulled HIGH on the target and pulled strong-LOW to initiate a reset. The polarity and strength of nSRST is configurable. |
| DBGREQ | Output | The Debug Request pin can be used to stop the target processor and put it into debug state. DBGREQ is rarely used by current systems and is usually pulled LOW on the target. |
| DBGACK | Input | The Debug Acknowledge pin can be used to notify DSTREAM that a debug request has been received and the target processor is now in debug state. DBGACK is rarely used by current systems and is usually pulled LOW on the target. |
| VTREF | Input | The Voltage Target Reference pin supplies DSTREAM with the debug rail voltage of the target to match its I/O logic levels. VTREF can be tied HIGH on the target. If VTREF is pulled HIGH by a resistor, its value must be no greater than 100Ω. |
| VSUPPLY | - | The Voltage Supply pin is not used by DSTREAM and must be left unconnected. |
| GND | - | Ground. |

3.8.1 See also

Concepts

- [Target connectors supported by DSTREAM on page 3-10](#)
- [I/O diagrams on page 3-33](#)
- [Voltage domains on page 3-36](#)
- [Series termination on page 3-37.](#)

Other information

- ETMv1 and ETMv3 architecture pinouts,
<http://infocenter.arm.com/help/topic/com.arm.doc.ih0014-/index.html>

3.9 ARM JTAG 20

The ARM JTAG 20 connector is a 20-way 2.54mm pitch connector. It can be used in either standard JTAG (IEEE 1149.1) mode or *Serial Wire Debug* (SWD) mode.

The following figure shows the ARM JTAG 20 connector pinout:

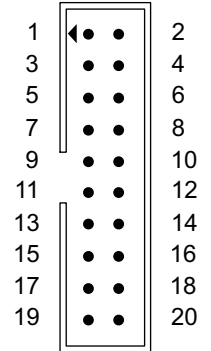

Figure 3-6 ARM JTAG 20 connector pinout

The following table shows the ARM JTAG 20 pinout as used on the target board:

Table 3-6 ARM JTAG 20 interface pinout table

| Pin | Signal name | I/O diagram | Voltage domain |
|-----|------------------|-------------|----------------|
| 1 | VTREF | F | A |
| 2 | NC | NA | NA |
| 3 | nTRST | D | A |
| 4 | GND | H | NA |
| 5 | TDI | B | A |
| 6 | GND | H | NA |
| 7 | TMS/SWDIO | B/C | A |
| 8 | GND | H | NA |
| 9 | TCK/SWCLK | B | A |
| 10 | GND | H | NA |
| 11 | RTCK | A | A |
| 12 | GND | H | NA |
| 13 | TDO/SWO | A | A |
| 14 | GND | H | NA |
| 15 | nSRST | E | A |
| 16 | GND | H | NA |
| 17 | DBGREQ | B | A |

Table 3-6 ARM JTAG 20 interface pinout table (continued)

| Pin | Signal name | I/O diagram | Voltage domain |
|-----|---------------|-------------|----------------|
| 18 | GND | H | NA |
| 19 | DBGACK | A | A |
| 20 | GND | H | NA |

The following table describes the signals on the ARM JTAG 20 interfaces:

Table 3-7 ARM JTAG 20 signals

| Signal | I/O | Description |
|---------------|--------------|---|
| TDI | Output | The Test Data In pin provides serial data to the target during debugging. TDI can be pulled HIGH on the target. |
| TDO | Input | The Test Data Out pin receives serial data from the target during debugging. You are advised to series terminate TDO close to the target processor. TDO is typically pulled HIGH on the target. |
| TMS | Output | The Test Mode Select pin is used to set the state of the <i>Test Access Port</i> (TAP) controller on the target. TMS can be pulled HIGH on the target to keep the TAP controller inactive when not in use. |
| TCK | Output | The Test Clock pin is used to clock data into the TDI and TMS inputs of the target. TCK is typically pulled HIGH on the target. |
| RTCK | Input | The Return Test Clock pin is used to echo the test clock signal back to DSTREAM for use with adaptive mode clocking. If RTCK is generated by the target processor, you are advised to series terminate it. RTCK can be pulled HIGH or LOW on the target when not in use. |
| nTRST | Output | The Test Reset pin can be used to reset the TAP controller of the processor to allow debugging to take place. nTRST is typically pulled HIGH on the target and pulled strong-LOW by DSTREAM to initiate a reset. The polarity and strength of nTRST is configurable. |
| nSRST | Input/Output | The System Reset pin is used to fully reset the target. This signal can be initiated by DSTREAM or by the target board (which is then detected by DSTREAM). nSRST is typically pulled HIGH on the target and pulled strong-LOW to initiate a reset. The polarity and strength of nSRST is configurable. |
| DBGREQ | Output | The Debug Request pin can be used to stop the target processor and put it into debug state. DBGREQ is rarely used by current systems and is usually pulled LOW on the target. |
| DBGACK | Input | The Debug Acknowledge pin can be used to notify DSTREAM that a debug request has been received and the target processor is now in debug state. DBGACK is rarely used by current systems and is usually pulled LOW on the target. |

Table 3-7 ARM JTAG 20 signals (continued)

| Signal | I/O | Description |
|-----------------------------|--------------|--|
| SWDIO (SWD mode) | Input/Output | The Serial Wire Data I/O pin sends and receives serial data to and from the target during debugging. You are advised to series terminate SWDIO close to the target processor. |
| SWCLK (SW D mode) | Output | The Serial Wire Clock pin clocks data into and out of the target during debugging. |
| SWO (SWD mode) | Input | The Serial Wire Output pin can be used to provide trace data to DSTREAM. You are advised to series terminate SWO close to the target processor. |
| VTREF | Input | The Voltage Target Reference pin supplies DSTREAM with the debug rail voltage of the target to match its I/O logic levels. VTREF can be tied HIGH on the target. If VTREF is pulled HIGH by a resistor, its value must be no greater than 100 Ω . |
| GND | - | Ground. |

3.9.1 See also

Concepts

- [Target connectors supported by DSTREAM on page 3-10](#)
- [I/O diagrams on page 3-33](#)
- [Voltage domains on page 3-36](#)
- [Series termination on page 3-37.](#)

Other information

- ETMv1 and ETMv3 architecture pinouts,
<http://infocenter.arm.com/help/topic/com.arm.doc.ih0014-/index.html>

3.10 TI JTAG 14

The TI JTAG 14 connector can be used in either standard JTAG (IEEE 1149.1) mode or *Serial Wire Debug* (SWD) mode.

The following figure shows the TI JTAG 14 connector pinout:

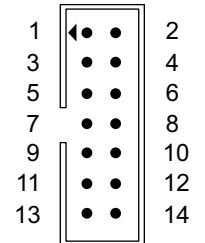

Figure 3-7 TI JTAG 14 connector pinout

The following table shows the TI JTAG 14 pinout as used on the target board:

Table 3-8 TI JTAG 14 interface pinout table

| Pin | Signal name | I/O diagram | Voltage domain |
|-----|------------------|-------------|----------------|
| 1 | TMS/SWDIO | B | A |
| 2 | nTRST | D | A |
| 3 | TDI | B | A |
| 4 | GND | H | NA |
| 5 | VTREF | F | A |
| 6 | NC | I | NA |
| 7 | TDO/SWO | A | A |
| 8 | GND | H | NA |
| 9 | RTCK | A | A |
| 10 | GND | H | NA |
| 11 | TCK/SWCLK | B | A |
| 12 | GND | H | NA |
| 13 | EMU0 | B | A |
| 14 | EMU1 | A | A |

The following table describes the signals on the TI JTAG 14 interfaces:

Table 3-9 TI JTAG 14 signals

| Signal | I/O | Description |
|----------------------------|--------------|--|
| TDI | Output | The Test Data In pin provides serial data to the target during debugging. TDI can be pulled HIGH on the target. |
| TDO | Input | The Test Data Out pin receives serial data from the target during debugging. You are advised to series terminate TDO close to the target processor. TDO is typically pulled HIGH on the target. |
| TMS | Output | The Test Mode Select pin is used to set the state of the <i>Test Access Port</i> (TAP) controller on the target. TMS can be pulled HIGH on the target to keep the TAP controller inactive when not in use. |
| TCK | Output | The Test Clock pin is used to clock data into the TDI and TMS inputs of the target. TCK is typically pulled HIGH on the target. |
| RTCK | Input | The Return Test Clock pin is used to echo the test clock signal back to DSTREAM for use with adaptive mode clocking. If RTCK is generated by the target processor, you are advised to series terminate it. RTCK can be pulled HIGH or LOW on the target when not in use. |
| nTRST | Output | The Test Reset pin can be used to reset the TAP controller of the processor to allow debugging to take place. nTRST is typically pulled HIGH on the target and pulled strong-LOW by DSTREAM to initiate a reset. The polarity and strength of nTRST is configurable. |
| EMU0 | - | The EMU0 pin is a general I/O pin but is not currently supported by DSTREAM. EMU0 can be pulled high, low or be left open-circuit on the target. |
| EMU1 | - | The EMU1 pin is a general I/O pin but is not currently supported by DSTREAM. EMU0 can be pulled high, low or be left open-circuit on the target. |
| SWDIO (SWD mode) | Input/Output | The Serial Wire Data I/O pin sends and receives serial data to and from the target during debugging. You are advised to series terminate SWDIO close to the target processor. |
| SWCLK (SWD mode) | Output | The Serial Wire Clock pin clocks data into and out of the target during debugging. |
| SWO (SWD mode) | Input | The Serial Wire Output pin can be used to provide trace data to DSTREAM. You are advised to series terminate SWO close to the target processor. |
| VTREF | Input | The Voltage Target Reference pin supplies DSTREAM with the debug rail voltage of the target to match its I/O logic levels. VTREF can be tied HIGH on the target. If VTREF is pulled HIGH by a resistor, its value must be no greater than 100Ω. |
| GND | - | Ground. |

3.10.1 See also

Concepts

- *Target connectors supported by DSTREAM* on page 3-10
- *I/O diagrams* on page 3-33
- *Voltage domains* on page 3-36
- *Series termination* on page 3-37.

Other information

- ETMv1 and ETMv3 architecture pinouts,
<http://infocenter.arm.com/help/topic/com.arm.doc.ih0014-/index.html>

3.11 ARM JTAG 14

The ARM JTAG 14 connector can be used in either standard JTAG (IEEE 1149.1) mode or *Serial Wire Debug* (SWD) mode.

The following figure shows the TI JTAG 14 connector pinout:

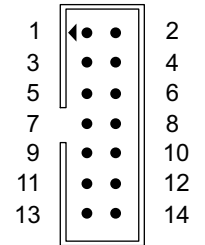

Figure 3-8 ARM JTAG 14 connector pinout

The following table shows the ARM JTAG 14 pinout as used on the target board:

Table 3-10 ARM JTAG 14 interface pinout table

| Pin | Signal name | I/O diagram | Voltage domain |
|-----|-------------|-------------|----------------|
| 1 | NC | NA | NA |
| 2 | GND | H | NA |
| 3 | nTRST | D | A |
| 4 | GND | H | NA |
| 5 | TDI | B | A |
| 6 | GND | H | NA |
| 7 | TMS/SWDIO | B | A |
| 8 | GND | H | NA |
| 9 | TCK/SWCLK | B | A |
| 10 | GND | H | NA |
| 11 | TDO/SWO | A | A |
| 12 | nSRST | E | A |
| 13 | VTREF | F | A |
| 14 | GND | H | NA |

The following table describes the signals on the ARM JTAG 14 interfaces:

Table 3-11 ARM JTAG 14 signals

| Signal | I/O | Description |
|-----------------------------|--------------|---|
| TDI | Output | The Test Data In pin provides serial data to the target during debugging. TDI can be pulled HIGH on the target. |
| TDO | Input | The Test Data Out pin receives serial data from the target during debugging. You are advised to series terminate TDO close to the target processor. TDO is typically pulled HIGH on the target. |
| TMS | Output | The Test Mode Select pin is used to set the state of the <i>Test Access Port</i> (TAP) controller on the target. TMS can be pulled HIGH on the target to keep the TAP controller inactive when not in use. |
| TCK | Output | The Test Clock pin is used to clock data into the TDI and TMS inputs of the target. TCK is typically pulled HIGH on the target. |
| nTRST | Output | The Test Reset pin can be used to reset the TAP controller of the processor to allow debugging to take place. nTRST is typically pulled HIGH on the target and pulled strong-LOW by DSTREAM to initiate a reset. The polarity and strength of nTRST is configurable. |
| nSRST | Input/Output | The System Reset pin is used to fully reset the target. This signal can be initiated by DSTREAM or by the target board (which is then detected by DSTREAM). nSRST is typically pulled HIGH on the target and pulled strong-LOW to initiate a reset. The polarity and strength of nSRST is configurable. |
| SWDIO (SWD mode) | Input/Output | The Serial Wire Data I/O pin sends and receives serial data to and from the target during debugging. You are advised to series terminate SWDIO close to the target processor. |
| SWCLK (SW D mode) | Output | The Serial Wire Clock pin clocks data into and out of the target during debugging. |
| SWO (SWD mode) | Input | The Serial Wire Output pin can be used to provide trace data to DSTREAM. You are advised to series terminate SWO close to the target processor. |
| VTREF | Input | The Voltage Target Reference pin supplies DSTREAM with the debug rail voltage of the target to match its I/O logic levels. VTREF can be tied HIGH on the target. If VTREF is pulled HIGH by a resistor, its value must be no greater than 100Ω. |
| GND | - | Ground. |

3.11.1 See also

Concepts

- [Target connectors supported by DSTREAM on page 3-10](#)
- [I/O diagrams on page 3-33](#)
- [Voltage domains on page 3-36](#)
- [Series termination on page 3-37.](#)

Other information

- ETMv1 and ETMv3 architecture pinouts,
<http://infocenter.arm.com/help/topic/com.arm.doc.ih0014-/index.html>

3.12 CoreSight 10

The CoreSight 10 connector can be used in either standard JTAG (IEEE 1149.1) mode or *Serial Wire Debug* (SWD) mode.

The following figure shows the CoreSight 10 connector pinout:

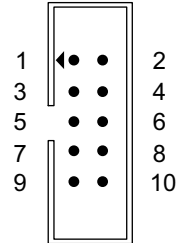

Figure 3-9 CoreSight 10 connector pinout

Note

A polarizing key is fitted only at the target end of the cable.

The following table shows the CoreSight 10 pinout as used on the target board:

Table 3-12 CoreSight 10 interface pinout table

| Pin | Signal name | I/O diagram | Voltage domain |
|-----|------------------|-------------|----------------|
| 1 | VTREF | G | A |
| 2 | TMS/SWDIO | B/C | A |
| 3 | GND | H | NA |
| 4 | TCK/SWCLK | B | A |
| 5 | GND | H | NA |
| 6 | TDO/SWO | A | A |
| 7 | KEY (NC) | NA | NA |
| 8 | TDI | B | A |
| 9 | GND | H | NA |
| 10 | nSRST | E | A |

The following table describes the signals on the CoreSight 10 interfaces:

Table 3-13 CoreSight 10 signals

| Signal | I/O | Description |
|----------------------------|--------------|---|
| TDI | Output | The Test Data In pin provides serial data to the target during debugging. TDI can be pulled HIGH on the target. |
| TDO | Input | The Test Data Out pin receives serial data from the target during debugging. You are advised to series terminate TDO close to the target processor. TDO is typically pulled HIGH on the target. |
| TMS | Output | The Test Mode Select pin is used to set the state of the <i>Test Access Port</i> (TAP) controller on the target. TMS can be pulled HIGH on the target to keep the TAP controller inactive when not in use. |
| TCK | Output | The Test Clock pin is used to clock data into the TDI and TMS inputs of the target. TCK is typically pulled HIGH on the target. |
| nSRST | Input/Output | The System Reset pin is used to fully reset the target. This signal can be initiated by DSTREAM or by the target board (which is then detected by DSTREAM). nSRST is typically pulled HIGH on the target and pulled strong-LOW to initiate a reset. The polarity and strength of nSRST is configurable. |
| SWDIO (SWD mode) | Input/Output | The Serial Wire Data I/O pin sends and receives serial data to and from the target during debugging. You are advised to series terminate SWDIO close to the target processor. |
| SWCLK (SWD mode) | Output | The Serial Wire Clock pin clocks data into and out of the target during debugging. |
| SWO (SWD mode) | Input | The Serial Wire Output pin can be used to provide trace data to DSTREAM. You are advised to series terminate SWO close to the target processor. |
| VTREF | Input | The Voltage Target Reference pin supplies DSTREAM with the debug rail voltage of the target to match its I/O logic levels. VTREF can be tied HIGH on the target. If VTREF is pulled HIGH by a resistor, its value must be no greater than 100Ω. |
| GND | - | Ground. |
| KEY | - | This pin must not be present on the target connector. |

3.12.1 See also

Concepts

- [Target connectors supported by DSTREAM on page 3-10](#)
- [I/O diagrams on page 3-33](#)
- [Voltage domains on page 3-36](#)
- [Series termination on page 3-37.](#)

Other information

- ETMv1 and ETMv3 architecture pinouts,
<http://infocenter.arm.com/help/topic/com.arm.doc.ih0014-/index.html>

3.13 CoreSight 20

The CoreSight 20 connector can be used in either standard JTAG (IEEE 1149.1) mode or *Serial Wire Debug* (SWD) mode. It can also optionally capture up to 4 bits of parallel trace in *Trace Port Interface Unit* (TPIU) continuous mode.

When this connector is configured to be a parallel trace source, pins 12 to 20 switch to their alternate trace functions.

The following figure shows the CoreSight 20 connector pinout:

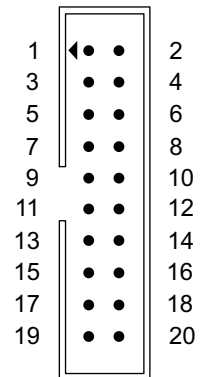

Figure 3-10 CoreSight 20 connector pinout

Note

A polarizing key is fitted only at the target end of the cable.

The following table shows the CoreSight 20 pinout as used on the target board:

Table 3-14 CoreSight 20 interface pinout table

| Pin | Signal name | I/O diagram | Voltage domain |
|-----|----------------------|-------------|----------------|
| 1 | VTREF | G | A |
| 2 | TMS/SWDIO | B/C | A |
| 3 | GND | H | NA |
| 4 | TCK/SWCLK | B | A |
| 5 | GND | H | NA |
| 6 | TDO/SWO | A | A |
| 7 | KEY (NC) | NA | NA |
| 8 | TDI | B | A |
| 9 | GND | H | NA |
| 10 | nSRST | E | A |
| 11 | NC | I | NA |
| 12 | RTCK/TRACECLK | A | A |
| 13 | NC | I | NA |

Table 3-14 CoreSight 20 interface pinout table (continued)

| Pin | Signal name | I/O diagram | Voltage domain |
|-----|------------------------|-------------|----------------|
| 14 | SWO/TraceD0 | E | A |
| 15 | GND | H | NA |
| 16 | nTRST/TraceD1 | E | A |
| 17 | GND | H | NA |
| 18 | DBGREQ/TraceD2 | A | A |
| 19 | GND | H | NA |
| 20 | DBGACK /TraceD3 | A | A |

The following table describes the signals on the CoreSight 20 interfaces:

Table 3-15 CoreSight 20 signals

| Signal | I/O | Description |
|---------------|--------------|---|
| TDI | Output | The Test Data In pin provides serial data to the target during debugging. TDI can be pulled HIGH on the target. |
| TDO | Input | The Test Data Out pin receives serial data from the target during debugging. You are advised to series terminate TDO close to the target processor. TDO is typically pulled HIGH on the target. |
| TMS | Output | The Test Mode Select pin is used to set the state of the <i>Test Access Port</i> (TAP) controller on the target. TMS can be pulled HIGH on the target to keep the TAP controller inactive when not in use. |
| TCK | Output | The Test Clock pin is used to clock data into the TDI and TMS inputs of the target. TCK is typically pulled HIGH on the target. |
| RTCK | Input | The Return Test Clock pin is used to echo the test clock signal back to DSTREAM for use with adaptive mode clocking. If RTCK is generated by the target processor, you are advised to series terminate it. RTCK can be pulled HIGH or LOW on the target when not in use. |
| nTRST | Output | The Test Reset pin can be used to reset the TAP controller of the processor to allow debugging to take place. nTRST is typically pulled HIGH on the target and pulled strong-LOW by DSTREAM to initiate a reset. The polarity and strength of nTRST is configurable. |
| nSRST | Input/Output | The System Reset pin is used to fully reset the target. This signal can be initiated by DSTREAM or by the target board (which is then detected by DSTREAM). nSRST is typically pulled HIGH on the target and pulled strong-LOW to initiate a reset. The polarity and strength of nSRST is configurable. |
| DBGREQ | Output | The Debug Request pin can be used to stop the target processor and put it into debug state. DBGREQ is rarely used by current systems and is usually pulled LOW on the target. |

Table 3-15 CoreSight 20 signals (continued)

| Signal | I/O | Description |
|------------------------------|--------------|---|
| DBGACK | Input | The Debug Acknowledge pin can be used to notify DSTREAM that a debug request has been received and the target processor is now in debug state. DBGACK is rarely used by current systems and is usually pulled LOW on the target. |
| SWDIO (SWD mode) | Input/Output | The Serial Wire Data I/O pin sends and receives serial data to and from the target during debugging. You are advised to series terminate SWDIO close to the target processor. |
| SWCLK (SWD mode) | Output | The Serial Wire Clock pin clocks data into and out of the target during debugging. |
| SWO (SWD mode) | Input | The Serial Wire Output pin can be used to provide trace data to DSTREAM. You are advised to series terminate SWO close to the target processor. SWO is configurable to be captured on pin 6 or 14. |
| TraceD[0-3] | Input | The Trace Data [0-3] pins provide DSTREAM with TPIU continuous mode trace data from the target. You are advised to series terminate these signals close to the target processor. |
| TRACECLK (Trace mode) | Input | The Trace Clock pin provides DSTREAM with the clock signal necessary to sample the trace data signals. You are advised to series terminate TRACECLK close to the target processor. |
| VTREF | Input | The Voltage Target Reference pin supplies DSTREAM with the debug rail voltage of the target to match its I/O logic levels. VTREF can be tied HIGH on the target. If VTREF is pulled HIGH by a resistor, its value must be no greater than 100Ω. |
| GND | - | Ground. |
| KEY | - | This pin must not be present on the target connector. |

3.13.1 See also

Concepts

- [Target connectors supported by DSTREAM on page 3-10](#)
- [I/O diagrams on page 3-33](#)
- [Voltage domains on page 3-36](#)
- [Series termination on page 3-37.](#)

Other information

- ETMv1 and ETMv3 architecture pinouts,
<http://infocenter.arm.com/help/topic/com.arm.doc.ih0014-/index.html>

3.14 MIPI 34

The MIPI 34 connector can be used in either standard JTAG (IEEE 1149.1) mode or *Serial Wire Debug* (SWD) mode. It can also capture up to 4-bits of parallel trace in *Trace Port Interface Unit* (TPIU) continuous mode.

This connector supports separate voltage domains for the debug and trace signals. It is therefore necessary to supply the appropriate voltages to both of the **VTREF** pins.

The following figure shows the MIPI 34 connector pinout:

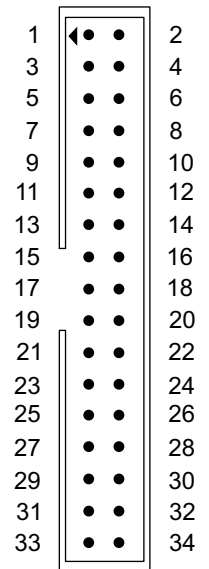

Figure 3-11 MIPI 34 connector pinout

Note

A polarizing key is fitted only at the target end of the cable.

The following table shows the MIPI 34 pinout as used on the target board:

Table 3-16 MIPI 34 interface pinout table

| Pin | Signal name | I/O diagram | Voltage domain |
|-----|------------------|-------------|----------------|
| 1 | VTREF | G | A |
| 2 | TMS/SWDIO | B | A |
| 3 | GND | H | NA |
| 4 | TCK/SWCLK | B | A |
| 5 | GND | H | NA |
| 6 | TDO/SWO | A | A |
| 7 | KEY (NC) | NA | NA |
| 8 | TDI | B | A |
| 9 | GND | H | NA |

Table 3-16 MIPI 34 interface pinout table (continued)

| Pin | Signal name | I/O diagram | Voltage domain |
|-----|-----------------|-------------|----------------|
| 10 | nSRST | E | A |
| 11 | NC | I | NA |
| 12 | RTCK | A | A |
| 13 | NC | I | NA |
| 14 | TRST_PD | D | A |
| 15 | GND | H | NA |
| 16 | nTRST | D | A |
| 17 | GND | H | NA |
| 18 | DBGREQ | B | A |
| 19 | GND | H | NA |
| 20 | DBGACK | A | A |
| 21 | GND | H | NA |
| 22 | TRACECLK | A | B |
| 23 | GND | H | NA |
| 24 | TRACED0 | A | B |
| 25 | GND | H | NA |
| 26 | TRACED1 | A | B |
| 27 | GND | H | NA |
| 28 | TRACED2 | A | B |
| 29 | GND | H | NA |
| 30 | TRACED3 | A | B |
| 31 | GND | H | NA |
| 32 | TRACEEXT | C | B |
| 33 | GND | H | NA |
| 34 | VTREF | F | B |

The following table describes the signals on the MIPI 34 interfaces:

Table 3-17 MIPI 34 signals

| Signal | I/O | Description |
|-------------------------|--------------|---|
| TDI | Output | The Test Data In pin provides serial data to the target during debugging. TDI can be pulled HIGH on the target. |
| TDO | Input | The Test Data Out pin receives serial data from the target during debugging. You are advised to series terminate TDO close to the target processor. TDO is typically pulled HIGH on the target. |
| TMS | Output | The Test Mode Select pin is used to set the state of the <i>Test Access Port</i> (TAP) controller on the target. TMS can be pulled HIGH on the target to keep the TAP controller inactive when not in use. |
| TCK | Output | The Test Clock pin is used to clock data into the TDI and TMS inputs of the target. TCK is typically pulled HIGH on the target. |
| RTCK | Input | The Return Test Clock pin is used to echo the test clock signal back to DSTREAM for use with adaptive mode clocking. If RTCK is generated by the target processor, you are advised to series terminate it. RTCK can be pulled HIGH or LOW on the target when not in use. |
| nTRST | Output | The Test Reset pin can be used to reset the TAP controller of the processor to allow debugging to take place. nTRST is typically pulled HIGH on the target and pulled strong-LOW by DSTREAM to initiate a reset. The polarity and strength of nTRST is configurable. |
| TRST_PD | Output | The Test Reset (Pull-Down) pin can be used to reset the TAP controller of the processor to allow debugging to take place. TRST_PD is typically pulled LOW on the target (reset state) and pulled strong-HIGH by DSTREAM to enable debugging. The polarity and strength of TRST_PD is configurable. |
| nSRST | Input/Output | The System Reset pin is used to fully reset the target. This signal can be initiated by DSTREAM or by the target board (which is then detected by DSTREAM). nSRST is typically pulled HIGH on the target and pulled strong-LOW to initiate a reset. The polarity and strength of nSRST is configurable. |
| DBGREQ | Output | The Debug Request pin can be used to stop the target processor and put it into debug state. DBGREQ is rarely used by current systems and is usually pulled LOW on the target. |
| DBGACK | Input | The Debug Acknowledge pin can be used to notify DSTREAM that a debug request has been received and the target processor is now in debug state. DBGACK is rarely used by current systems and is usually pulled LOW on the target. |
| SWDIO (SWD mode) | Input/Output | The Serial Wire Data I/O pin sends and receives serial data to and from the target during debugging. You are advised to series terminate SWDIO close to the target processor. |
| SWCLK (SWD mode) | Output | The Serial Wire Clock pin clocks data into and out of the target during debugging. |

Table 3-17 MIPI 34 signals (continued)

| Signal | I/O | Description |
|-----------------------|-------|--|
| SWO (SWD mode) | Input | The Serial Wire Output pin can be used to provide trace data to DSTREAM. You are advised to series terminate SWO close to the target processor. |
| TraceD[0-3] | Input | The Trace Data [0-3] pins provide DSTREAM with <i>Trace Port Interface Unit</i> (TPIU) continuous mode trace data from the target. You are advised to series terminate these signals close to the target processor. |
| TRACECLK | Input | The Trace Clock pin provides DSTREAM with the clock signal necessary to sample the trace data signals. You are advised to series terminate TRACECLK close to the target processor. |
| TRACEEXT | Input | The Trace Extension pin is a generic trace sideband pin. TRACEEXT is not currently supported by DSTREAM. TRACEEXT can be pulled high, low, or left unconnected on the target. |
| VTREF | Input | The Voltage Target Reference pin supplies DSTREAM with the debug rail voltage of the target to match its I/O logic levels. VTREF can be tied HIGH on the target. If VTREF is pulled HIGH by a resistor, its value must be no greater than 100 Ω . |
| GND | - | Ground. |
| KEY | - | This pin must not be present on the target connector. |

3.14.1 See also

Concepts

- [Target connectors supported by DSTREAM on page 3-10](#)
- [I/O diagrams on page 3-33](#)
- [Voltage domains on page 3-36](#)
- [Series termination on page 3-37.](#)

Other information

- ETMv1 and ETMv3 architecture pinouts, <http://infocenter.arm.com/help/topic/com.arm.doc.ih0014-/index.html>

3.15 I/O diagrams

The pin I/O circuit diagrams for the debug and trace connectors on the DSTREAM probe are:

Diagram A - Input

The input circuit diagram is shown in the following figure:

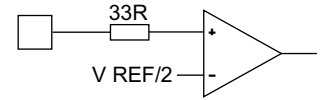

Figure 3-12 Input

Diagram B - Output

The output circuit diagram is shown in the following figure:

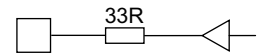

Figure 3-13 Output

Diagram C - Input/Output

The input/output circuit diagram is shown in the following figure:

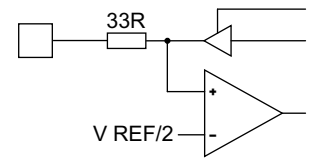

Figure 3-14 Input/Output

Diagram D - Reset output

The reset output circuit diagram is shown in the following figure:

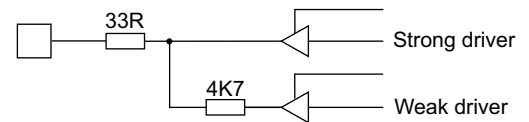

Figure 3-15 Reset output

Diagram E - Reset output with feedback

The reset output with feedback circuit diagram is shown in the following figure:

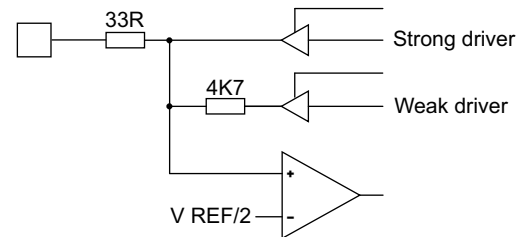

Figure 3-16 Reset output with feedback

Diagram F - VTRef input

The VTRef input circuit diagram is shown in the following figure:

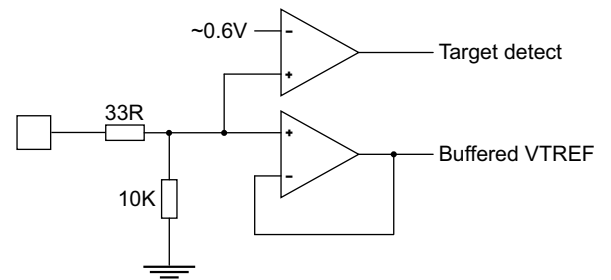

Figure 3-17 VTRef input

Diagram G - VTRef input (decoupled)

The VTRef input (decoupled) circuit diagram is shown in the following figure:

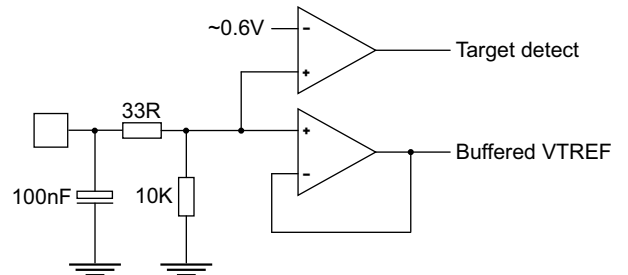

Figure 3-18 VTRef input (decoupled)

Diagram H - Ground

The Ground circuit diagram is shown in the following figure:

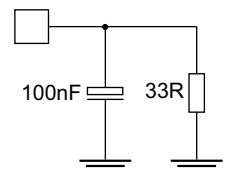

Figure 3-19 Ground

Diagram I - AC Ground

The AC Ground circuit diagram is shown in the following figure:

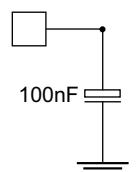

Figure 3-20 AC Ground

3.15.1 See also**Concepts**

- [Target connectors supported by DSTREAM on page 3-10](#)
- [Voltage domains on page 3-36](#)
- [Series termination on page 3-37.](#)

Other information

- ETMv1 and ETMv3 architecture pinouts,
<http://infocenter.arm.com/help/topic/com.arm.doc.ih0014-/index.html>

3.16 Voltage domains

The DSTREAM probe supports two separate voltage domains to work with debug and trace interfaces on differing voltage rails.

Voltage domain A is used by the following connectors:

- ARM JTAG 20
- TI JTAG 14
- ARM JTAG 14
- CoreSight 10
- CoreSight 20
- MIPI 34.

Voltage domain B is used by the following connectors:

- Mictor 38
- MIPI 34.

The MIPI 34 connector is the only one which supports both voltage domains, and is equipped with two VTREF pins to achieve the correct logic levels.

The VTREF A and VTREF B LEDs on the probe indicate when targets have been detected in the respective voltage domains.

3.16.1 See also

Concepts

- [Target connectors supported by DSTREAM on page 3-10](#)
- [Series termination on page 3-37.](#)

3.17 Series termination

Series (or source) termination is a technique employed in point-to-point signaling to ensure that no excessive overshoot or ringing occurs. This is achieved by reducing the source voltage by approximately 50% close to the driver. When the signal reaches the end of the transmission line, the high impedance of the receiver causes a reflection which approximately doubles the signal back to its original amplitude. When the reflection returns to the series terminating resistor, the potential across the resistor drops to zero which prevents any more current from entering the transmission line. From the perspective of the receiver, this gives a perfect 100% logic transition without any overshoot or ringing.

It is recommended that all outputs from the target system be simulated to ensure that a reliable signal is delivered to the DSTREAM probe. Some overshoot/undershoot is acceptable but it is recommended to keep this below ~0.5V. Beyond this point, the clamping diodes at the receivers will start to cause high transient currents which in turn cause increased crosstalk, radio emissions and target power usage.

The target signal impedance for use with DSTREAM is 50Ω.

The following table lists some typical series terminating resistor values for instances when the outputs cannot be simulated.

Table 3-18 Typical series terminating resistor values

| Driver strength | Typical series terminator | |
|-----------------|---------------------------|--------------------------------------|
| 32mA | 39Ω | Best signal integrity, highest speed |
| 24mA | 33Ω | |
| 16mA | 27Ω | |
| 12mA | 22Ω | |
| 8mA | 15Ω | |
| 6mA | 10Ω | Worst signal integrity, lowest speed |

Some types of IC use “impedance matched” outputs to improve their signal integrity. This is usually achieved by using weaker drive transistors to slow down the edge transitions. This has the side effect of limiting the data throughput of the driver.

To achieve the highest data rates with the best signal integrity, it is recommended to use a strong and fast driver and appropriate series terminating resistor.

If it is determined that series terminating resistors are not required, it is recommended that 0Ω links be placed close to the driver as a fall-back option.

When series terminating multiple signals, it is common to use small quad resistor packages. This saves board space and reduces parasitic effects without much risk of placement or tombstoning issues during production.

3.17.1 See also

Concepts

- [Target connectors supported by DSTREAM on page 3-10](#)
- [Voltage domains on page 3-36](#).

Chapter 4

ARM DSTREAM User I/O Connections

The following topic describes the additional input and output connections provided in DSTREAM, and consists of:

- [The User I/O connector on page 4-2.](#)

4.1 The User I/O connector

The User *Input/Output* (I/O) connector is situated on an end panel of the DSTREAM unit. The connector is a 10-way 2.54mm pitch *Insulation Displacement Connector* (IDC) header that mates with IDC sockets mounted on a ribbon cable, as shown in the following figure.

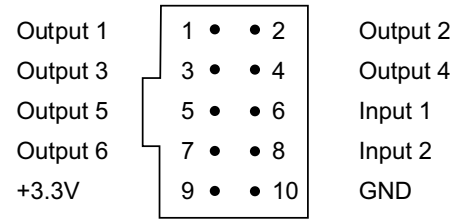

Figure 4-1 User I/O pin connections

Warning

You must establish a common ground between the unit and the target hardware before you connect any of the User I/O signals.

The following table shows the User I/O pin connections.

Table 4-1 User I/O pin connections

| Pin | Signal | I/O | Description |
|-------|-----------------|--------|--|
| Pin 1 | Output 1 | Output | This is a user output bit. It operates at a 3.3V swing, with a 100Ω series resistance. |
| Pin 2 | Output 2 | Output | This is a user output bit. It operates at a 3.3V swing, with a 100Ω series resistance. |
| Pin 3 | Output 3 | Output | This is a user output bit. It operates at a 3.3V swing, with a 100Ω series resistance. |
| Pin 4 | Output 4 | Output | This is a user output bit. It operates at a 3.3V swing, with a 100Ω series resistance. |
| Pin 5 | Output 5 | Output | This is a user output bit. It operates at a 3.3V swing, with a 100Ω series resistance. |
| Pin 6 | Input 1 | Input | This is a user input bit. It has a 100K weak pull-up to the unit internal +3.3V supply, and requires a $V_{ih(min)}$ of 2.0V and a $V_{il(max)}$ of 0.8V. It can safely be driven by 5V logic levels, and has <i>Electro Static Discharge</i> (ESD) protection greater than the 2kV human body model. This pin is not currently supported. |
| Pin 7 | Output 6 | Output | This is a user output bit. It operates at a 3.3V swing, with a 100Ω series resistance. |

Table 4-1 User I/O pin connections (continued)

| Pin | Signal | I/O | Description |
|--------|----------------|--------|---|
| Pin 8 | Input 2 | Input | This is a copy of the trigger input on the end panel of the DSTREAM unit. It has a 10k Ω weak pull-up to the unit internal +3.3V supply, and requires a $V_{ih(min)}$ of 2.0V and a $V_{il(max)}$ of 0.8V. It can safely be driven by 5V logic levels, and has ESD protection greater than the 2kV human body model. This pin is not currently supported. |
| Pin 9 | +3.3V | Output | This is intended as a voltage reference for external circuitry and is current limited to approximately 50mA. |
| Pin 10 | GND | - | - |

Note

Input is not currently supported on the User I/O pin connections.

4.1.1 See also**Reference**

Setting Up the ARM DSTREAM™ Hardware:

- [The DSTREAM unit on page 2-5.](#)

Chapter 5

Designing the Target Board for Tracing with ARM DSTREAM

The following topics provide information on the properties of a target board that can be connected to the trace feature:

- *Overview of high-speed design* on page 5-2
- *PCB track impedance* on page 5-3
- *Signal requirements* on page 5-4
- *Probe modeling* on page 5-5.

5.1 Overview of high-speed design

Failure to observe high-speed design rules when designing a target system containing an ARM® *Embedded Trace Macrocell* (ETM) trace port can result in incorrect trace data being captured. You must give serious consideration to high-speed signals when designing the target system.

The signals coming from an ETM trace port can have very fast rise and fall times, even at relatively low frequencies. For example, a signal with a rise time of 1ns has an effective knee frequency of 500MHz and a signal with a rise time of 500ps has an effective knee frequency of 1GHz ($f_{\text{knee}} = 0.5/\text{Tr}$).

Note

These principles apply to all of the trace port signals, but special care must be taken with **TRACECLK**.

You must make the following considerations for high-speed design:

Avoid stubs

Stubs are short pieces of track that tee off from the main track carrying the signal to, for example, a test point or a connection to an intermediate device. Stubs cause impedance discontinuities that affect signal quality and must be avoided.

Special care must therefore be taken when ETM signals are multiplexed with other pin functions and where the PCB is designed to support both functions with differing tracking requirements.

Minimize signal skew (balancing PCB track lengths)

You must attempt to match the lengths of the PCB tracks carrying the trace port signals from the ASIC to the Mictor connector to within approximately 0.5 inches (12.5mm) of each other. Any greater differences directly impact the setup and hold time requirements.

Minimize crosstalk

Normal high-speed design rules must be observed. For example, do not run dynamic signals parallel to each other for any significant distance, keep them spaced well apart, and use a ground plane and so forth. Particular attention must be paid to the **TRACECLK** signal. If in any doubt, place grounds or static signals between the **TRACECLK** and any other dynamic signals.

Use impedance matching and termination

All PCB tracks carrying trace port signals must be impedance matched to approximately 50Ω. Series termination is highly recommended on all high-speed signals.

5.1.1 See also

Concepts

- [Series termination on page 3-37](#)
- [PCB track impedance on page 5-3](#)
- [Signal requirements on page 5-4](#)
- [Probe modeling on page 5-5](#)

5.2 PCB track impedance

Use the following formula only for microstrips (track on outer layer over a ground plane):

$$\text{Impedance} = \frac{87}{\sqrt{(E_r + 1.41)}} \ln \left[\frac{5.98h}{(0.81w + t)} \right] \Omega$$

where:

| | |
|-------|--|
| h | Height above ground plane (inches) |
| w | Trace width (inches), and $0.1 < w/h < 2$ |
| t | Trace thickness (inches) |
| E_r | Relative permittivity of processor/prepreg, and $1 < E_r < 15$ |

The dimensions h, w, and t are shown in the following figure.

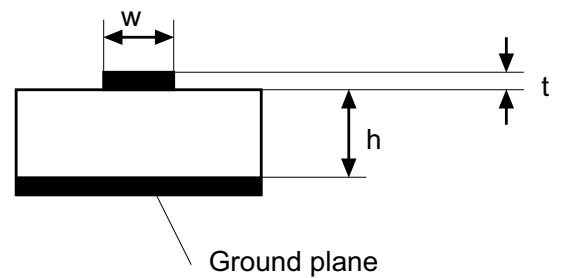

Figure 5-1 Track impedance

As an example, the following track (in microstrip form) has an impedance of 51.96Ω:

| | |
|-------|---|
| h | 0.005 inch height above ground |
| w | 0.007 inch width track |
| t | 0.0014 inch thickness (1 oz. finished weight) |
| E_r | 4.5 (FR4 laminate) |

———— **Note** ————

As the track width increases, the impedance decreases.

5.2.1 See also

Concepts

- [Series termination on page 3-37](#)
- [Overview of high-speed design on page 5-2](#)
- [Signal requirements on page 5-4](#)
- [Probe modeling on page 5-5.](#)

5.3 Signal requirements

The data setup and hold requirements and switching thresholds for ARM DSTREAM™ are:

5.3.1 Data setup and hold

The following figure and table show the setup and hold timing of the trace signals with respect to **TRACECLK**.

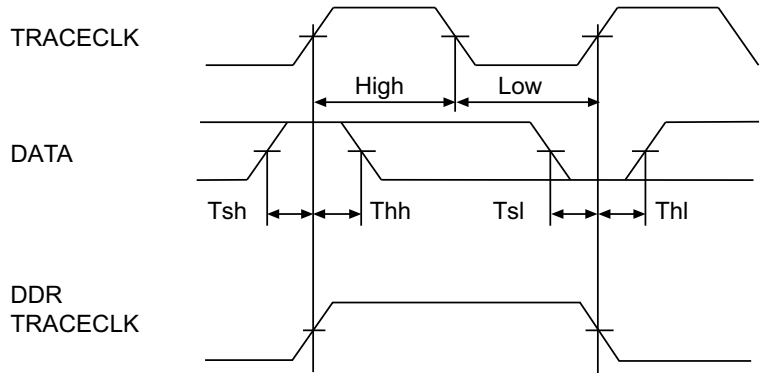

Figure 5-2 Data waveforms

Table 5-1 Data setup and hold

| Parameter | DSTREAM | Description |
|-----------|---------|-----------------|
| Tsh (min) | 0.75ns | Data setup high |
| Thh (min) | 0.75ns | Data hold high |
| Tsl (min) | 0.75ns | Data setup low |
| Thl (min) | 0.75ns | Data hold low |

Note

DSTREAM supports DDR clocking mode. Data is output on each edge of the **TRACECLK** signal and **TRACECLK (max) <= 300MHz**.

5.3.2 Switching Thresholds

The DSTREAM probe senses the target signaling reference voltage (VTref) and automatically adjusts its switching thresholds to VTref/2. For example, on a 3.3 volt target system, the switching thresholds are set to 1.65 volts.

5.3.3 See also

Concepts

- [Hot-plugging on page 3-8](#)
- [Series termination on page 3-37](#)
- [Overview of high-speed design on page 5-2](#)
- [PCB track impedance on page 5-3](#)
- [Probe modeling on page 5-5](#).

5.4 Probe modeling

For trace bit rates of 0-600Mbps, basic signal integrity can be established using simplified modeling. The bulk of the transmission line model consists of the cable being used between the probe and target.

The Mictor cable is made using micro-coax and can be modeled as a 50Ω transmission line with a 1.5ns propagation delay and 0.6Ω DC resistance. The connectors at either end can be modeled as a 0.3pF capacitance to ground.

The CoreSight/MIPI cables are made using 0.635mm pitch ribbon and can be modeled as a 66Ω transmission line with a 1.5ns propagation delay and 0.4Ω DC resistance. The connectors at either end can be modeled as a 0.5pF capacitance to ground.

The JTAG 20 and JTAG 14 cables are made using 1.27mm pitch ribbon and can be modeled as a 100Ω transmission line with a 1.5ns propagation delay and 0.1Ω DC resistance. The connectors at either end can be modeled as a 1.0pF capacitance to ground.

The circuit at the probe end of the transmission line can be modeled using the following primitives:

- All resistors can be modeled as their ideal resistance values with minimum/zero parasitics.
- All capacitors can be modeled as their ideal capacitance values with minimum/zero parasitics.
- Input comparators can be modeled using the Spartan 3 SSTLx_I model. The switching threshold can be assumed to be half of the VTref voltage as supplied by the target and data can be assumed to be valid when it is 100mV above or below this threshold.
- Output drivers can be modeled using the Spartan 3 LVCMOS Fast 16mA model. The model voltage must be chosen to match the target system voltage.

All other parasitics and traces within the probe are negligible for most practical purposes.

You are strongly advised to use series termination on all target outputs to achieve good signal integrity.

5.4.1 See also

Concepts

- [I/O diagrams on page 3-33](#)
- [Series termination on page 3-37](#)
- [Overview of high-speed design on page 5-2](#)
- [PCB track impedance on page 5-3](#)
- [Signal requirements on page 5-4.](#)

Other information

- ARM® tools and models, <http://www.arm.com/products>
- Xilinx, <http://www.xilinx.com>